

Towards Online Detection of Tire Wear Particles: Mass Spectrometric Challenges and Future Directions



Nikita Sobolev, Elin Stockinger Schibbye, Felix Benjamin Blixt Hasle, Keerthana Balashankar,
Tomas Mikoviny and Armin Wisthaler

Department of Chemistry, University of Oslo
Bedre Byluftforum

15 April 2026



TWPs are a significant fraction of microplastics

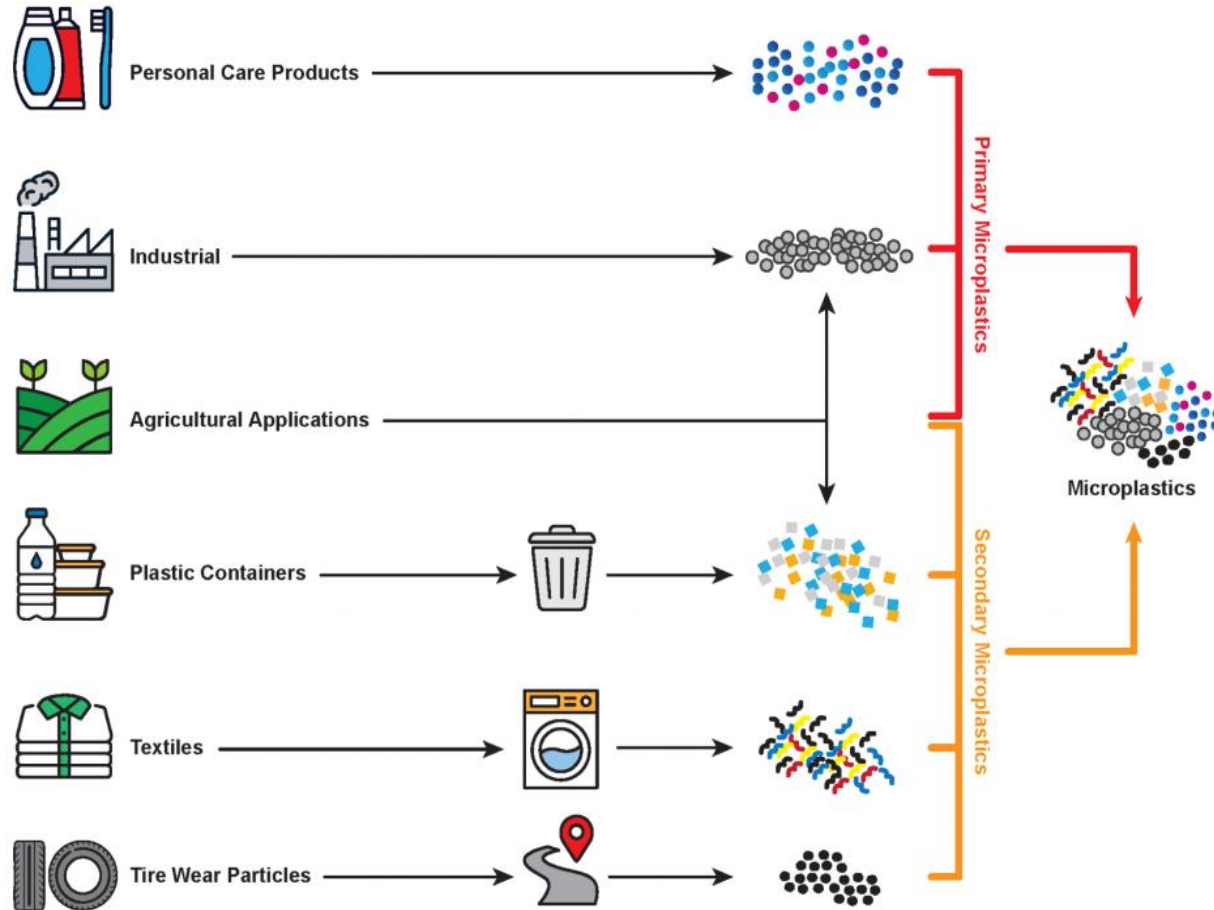

- Becoming more prevalent due to the increasing use of electric vehicles
- Diverse in size
- Complex matrix consist of polymers (rubber), organic additives and inorganic components such as carbon black and zinc oxide

ITRC MP Figure 2-1
Source: J. McDonald

Methodological approach

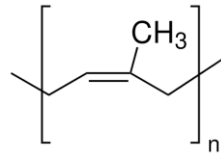

Polyisoprene (PIR)

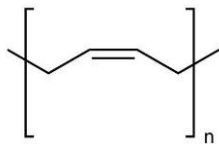

Polybutadiene (PBR)

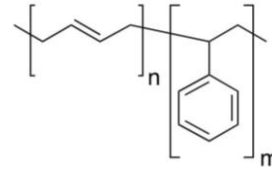

Poly(styrene-butadiene) (SBR)

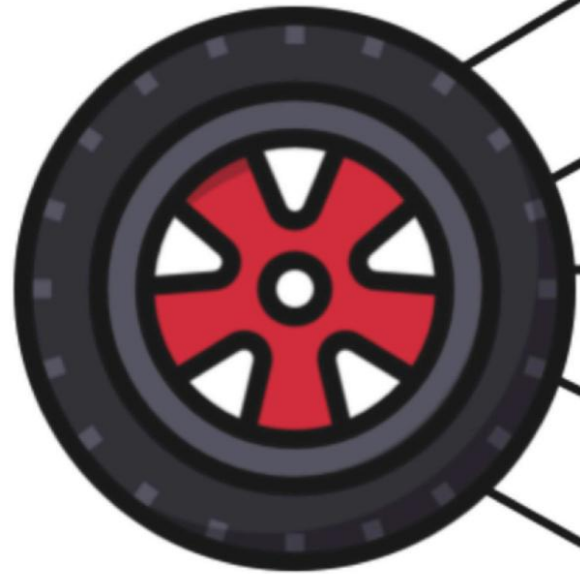

40-50%

Polymeric material

30-35%

Fillers

15%

Softeners

2-5%

Vulcanization agents

5-10%

Other Additives

1. Detect synthetic rubber material in airborne PM

Pyrolysis PTR-QMS, Pyr-GC-MS

Why Online Detection?

2. Detect 6PPD in airborne PM as a specific tire wear marker

Thermal desorption PTR-ToF-MS, UHPLC-Orbitrap

Johannessen C., et al., Atmospheric Pollution Research., 2022.

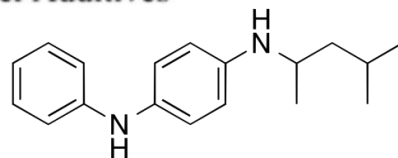

6PPD (antiozonant)

Proton Transfer Reaction Mass Spectrometry PTR-MS

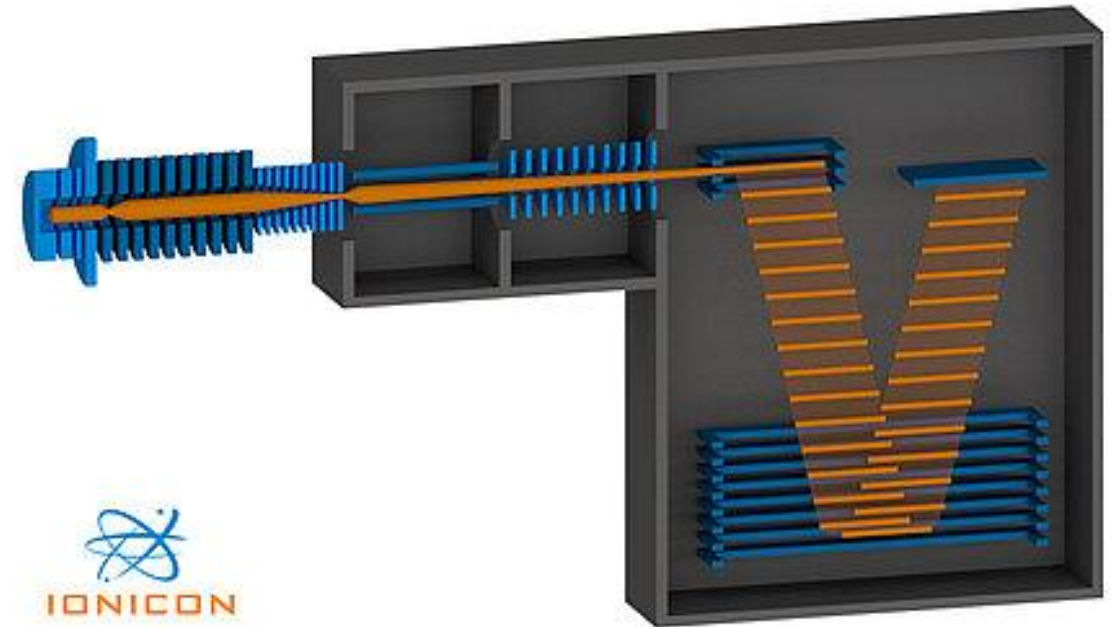
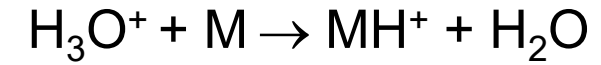
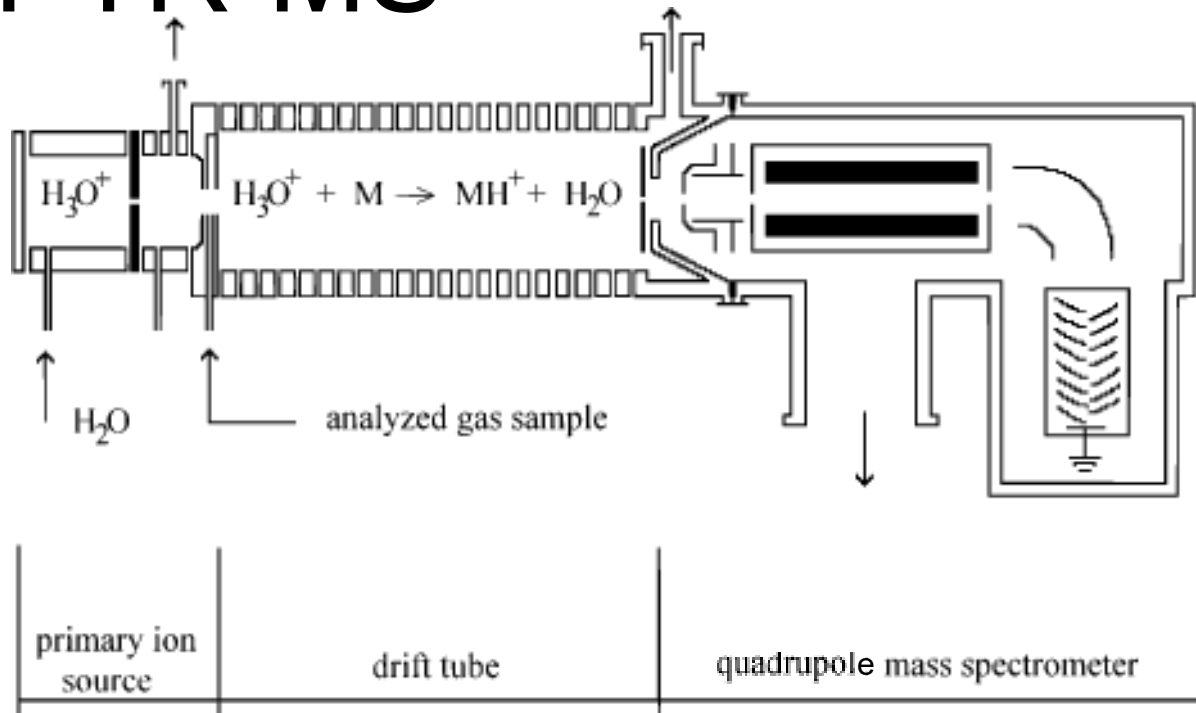

<https://www.ionicon.com/technologies/details/expert-information>

Amann A., et al., Measurement Science Review., 2010.

Online mass spectrometry for analysis of gaseous samples

Soft ionization with formation of MH^+ and low fragmentation

pptV level detection limit and up to 10000 $\text{m}/\Delta\text{m}$ resolution

Pyrolysis PTR-MS

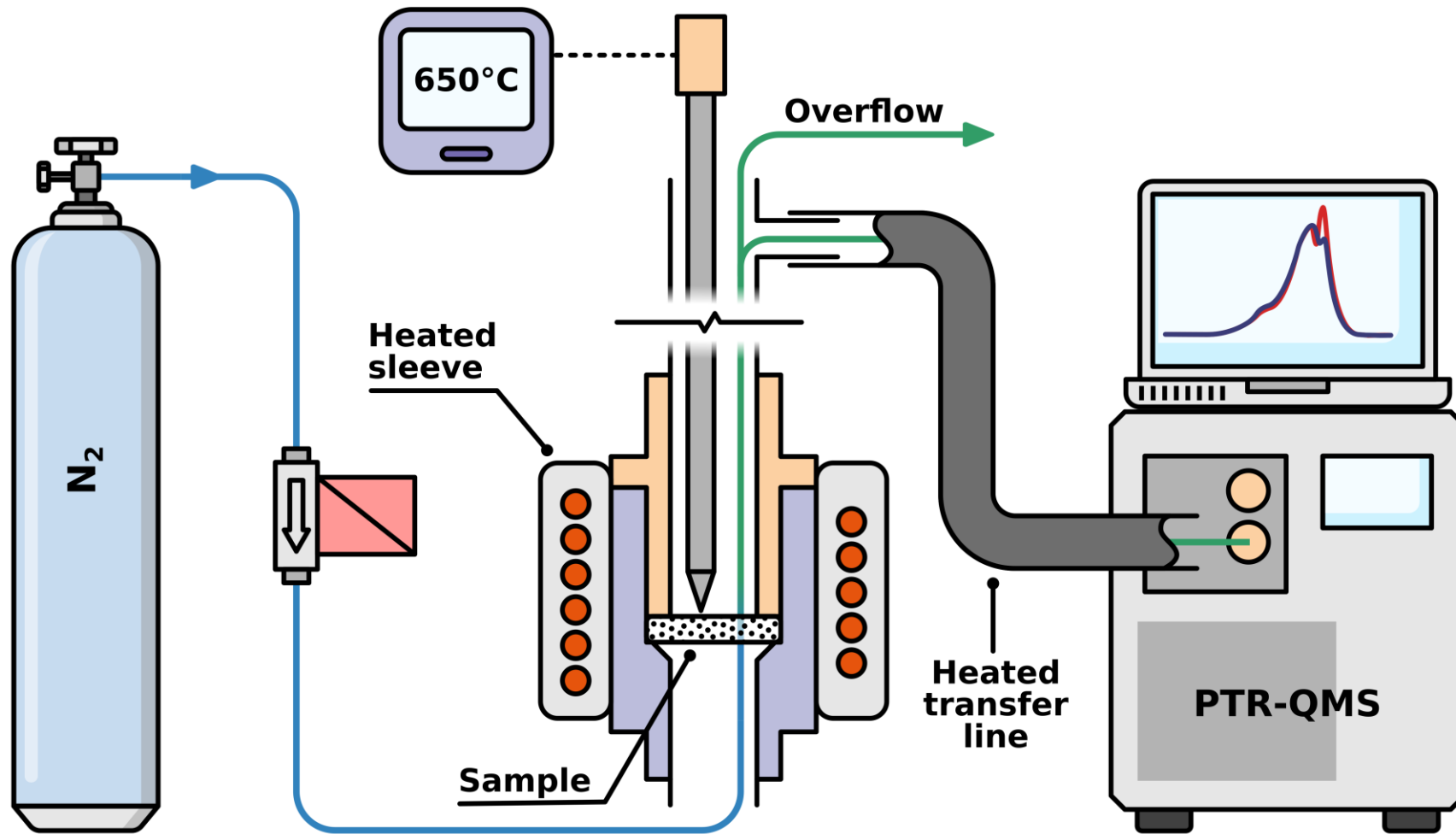

Pyrolysis PTR-MS

Styrene – butadiene rubber (SBR)

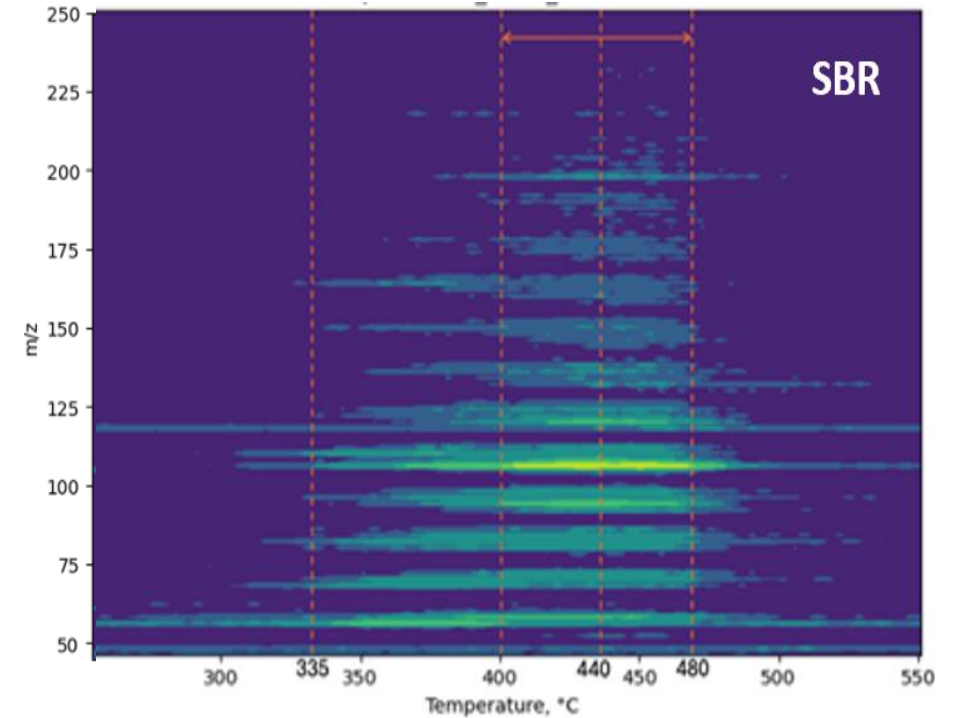
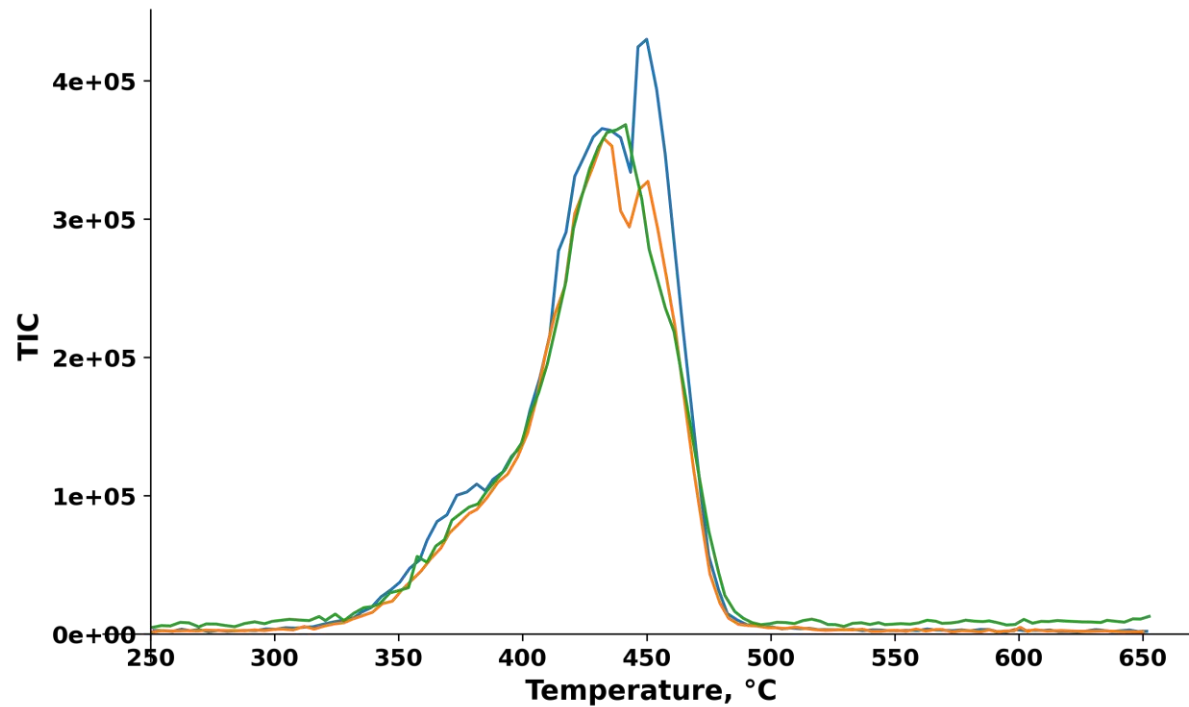

Pyrolysis PTR-MS

PBR – polybutadiene rubber, **SBR** – poly styrene-butadiene rubber
PIR – polyisoprene rubber, **CMTT** – cryomilled tire particles

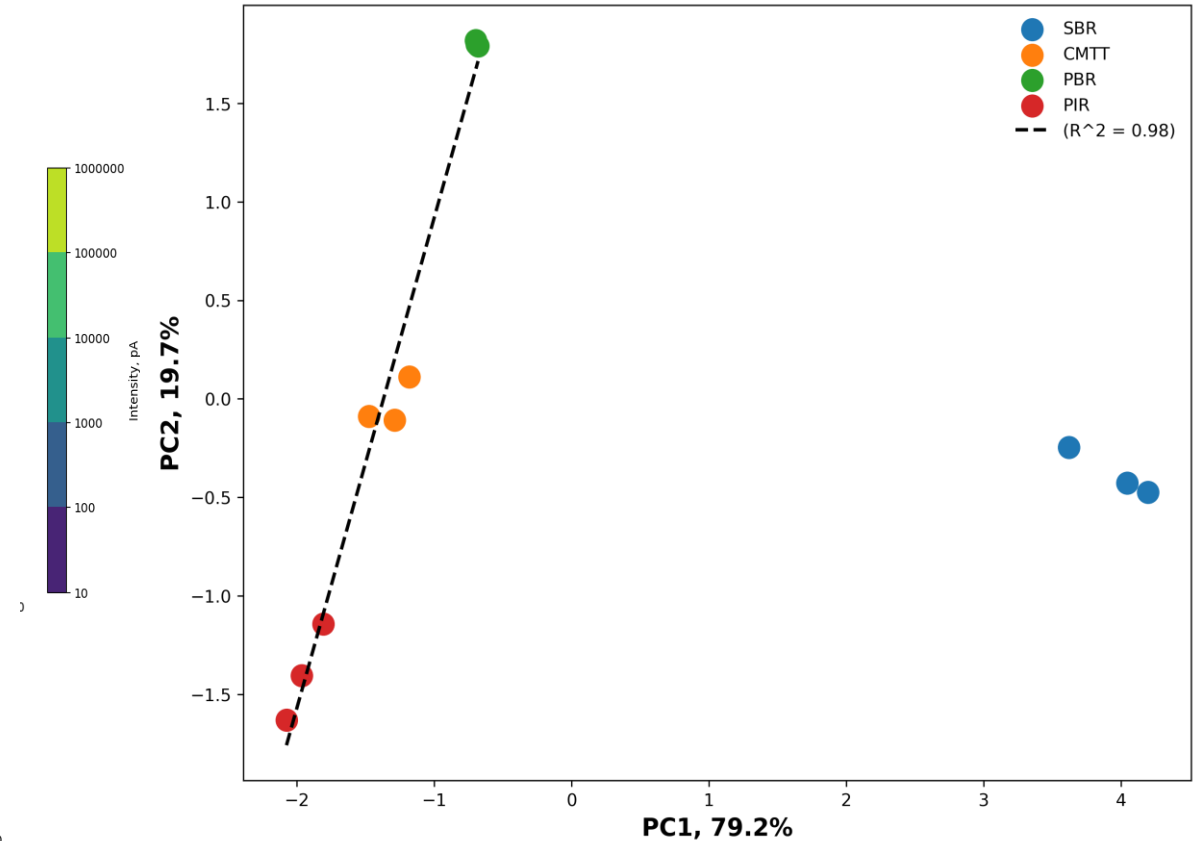
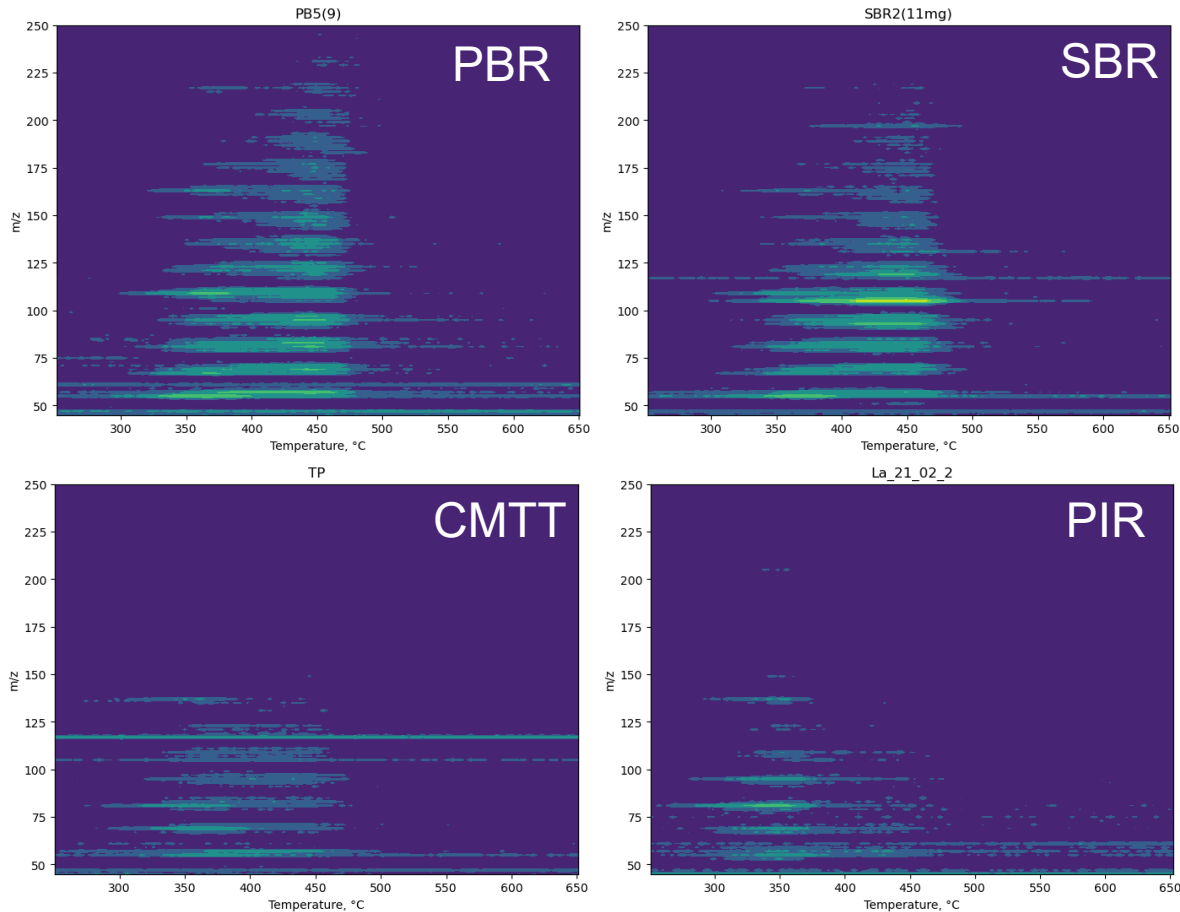

Different types of rubber generate distinct “fingerprint” mass spectra
This method has not yet been tested on ambient air filter samples

Thermal desorption PTR-ToF-MS

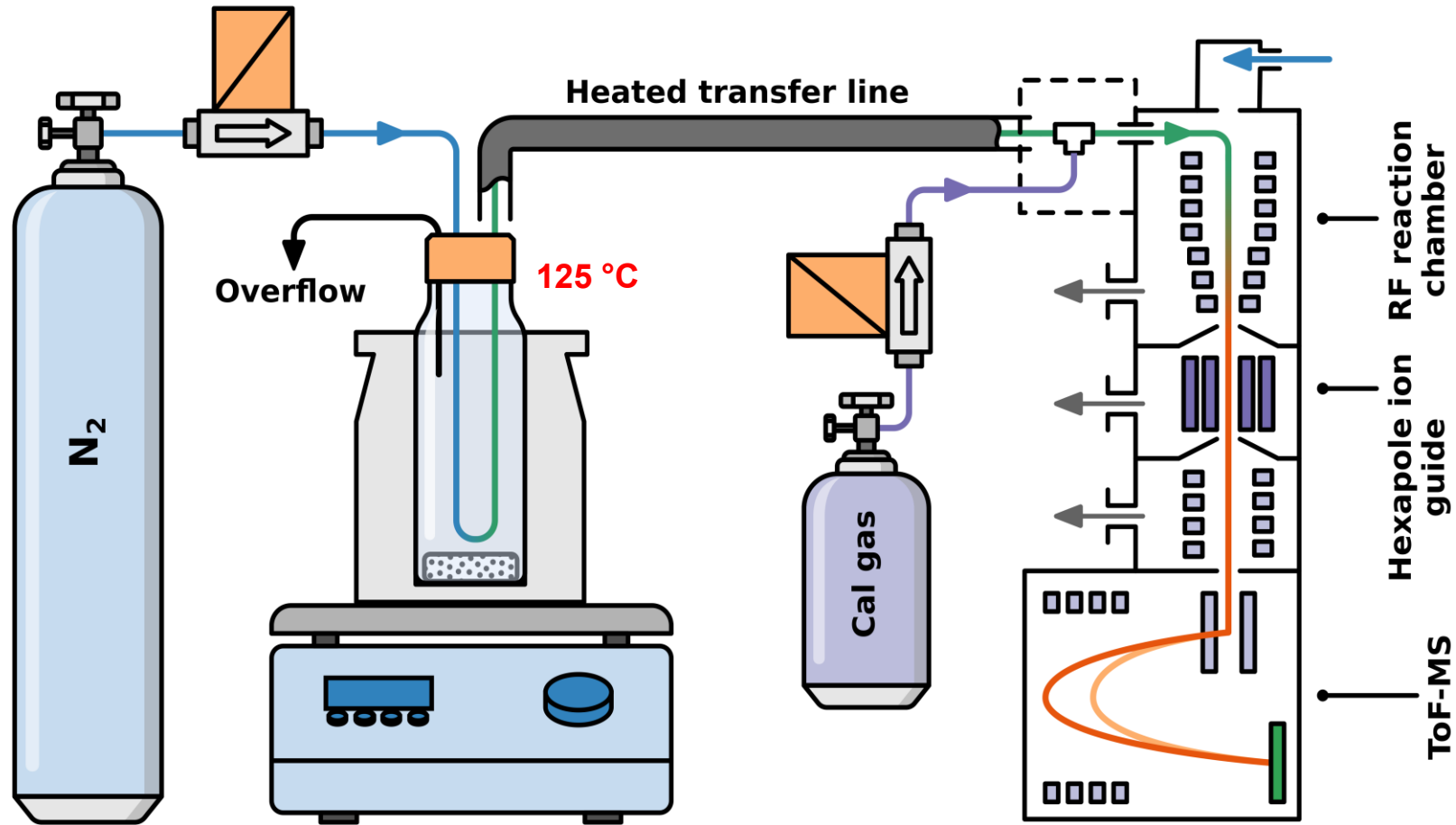

PTR-ToF mass spectrum of pure 6PPD

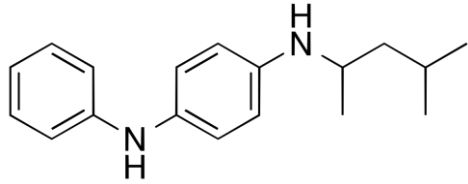

[M+H]⁺ : *m/z* 269.201
(little fragmentation)

common rubber antiozonant in vehicle tires

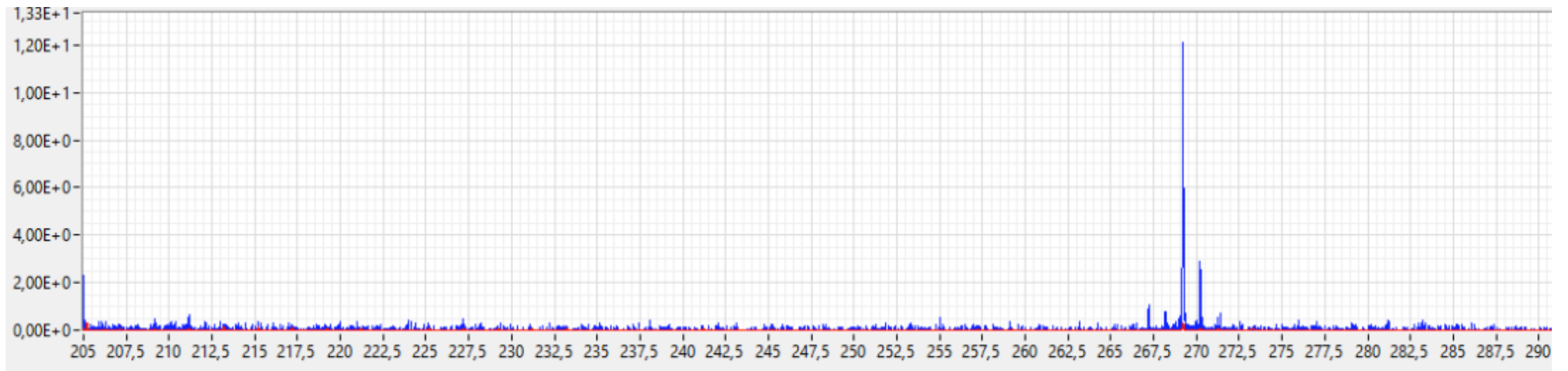

PTR-ToF mass spectrum of cryo-milled TWP

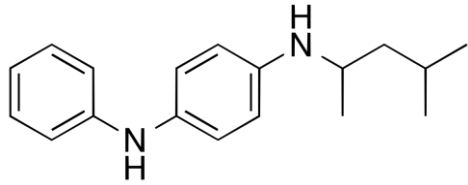

$[M+H]^+ : m/z 269.201$

common rubber antiozonant in vehicle tires

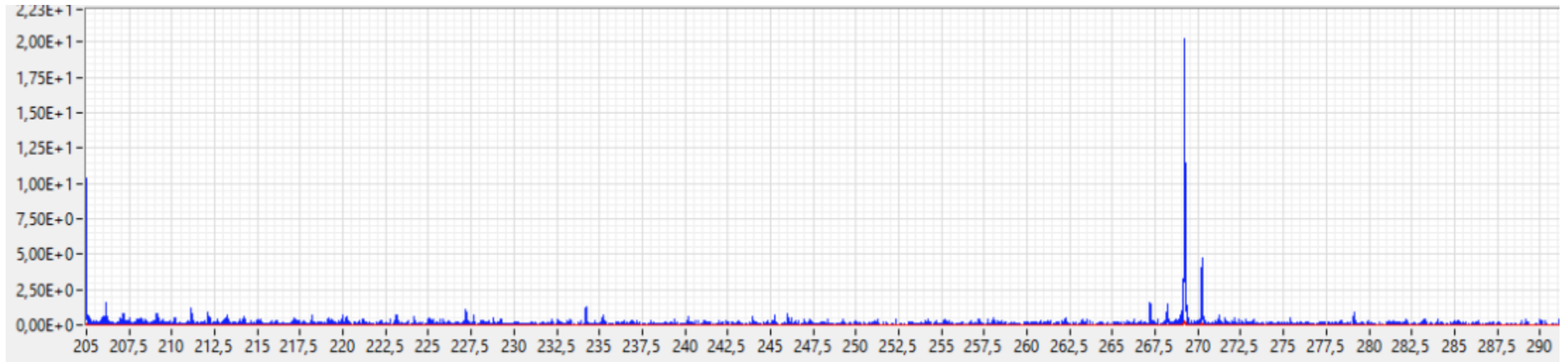

PTR-ToF mass spectrum of ambient air PM

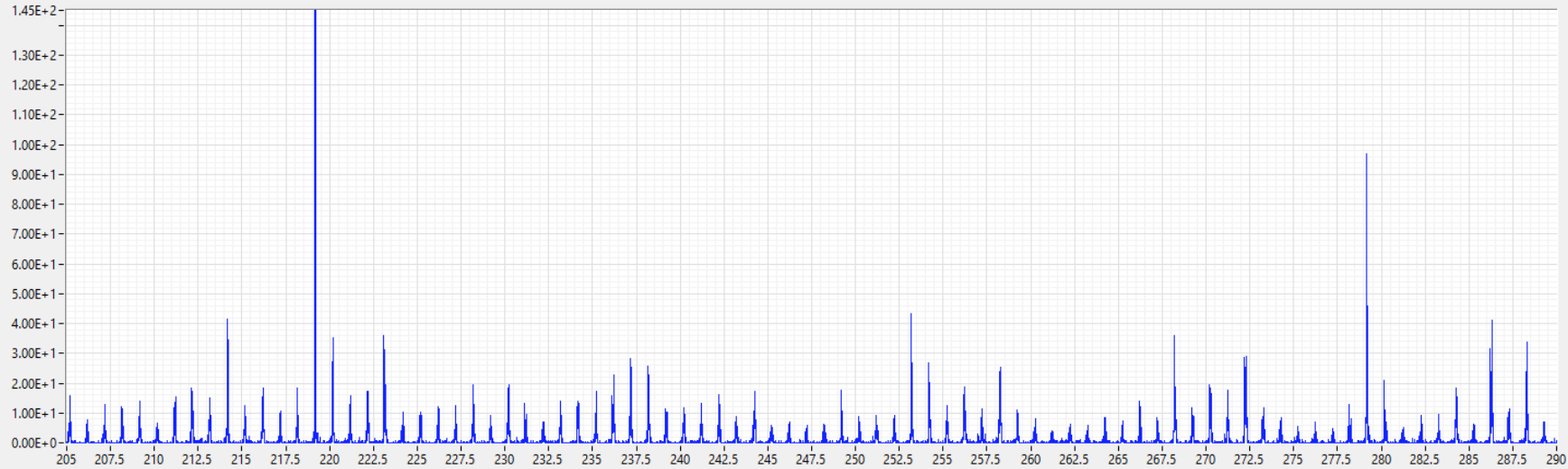
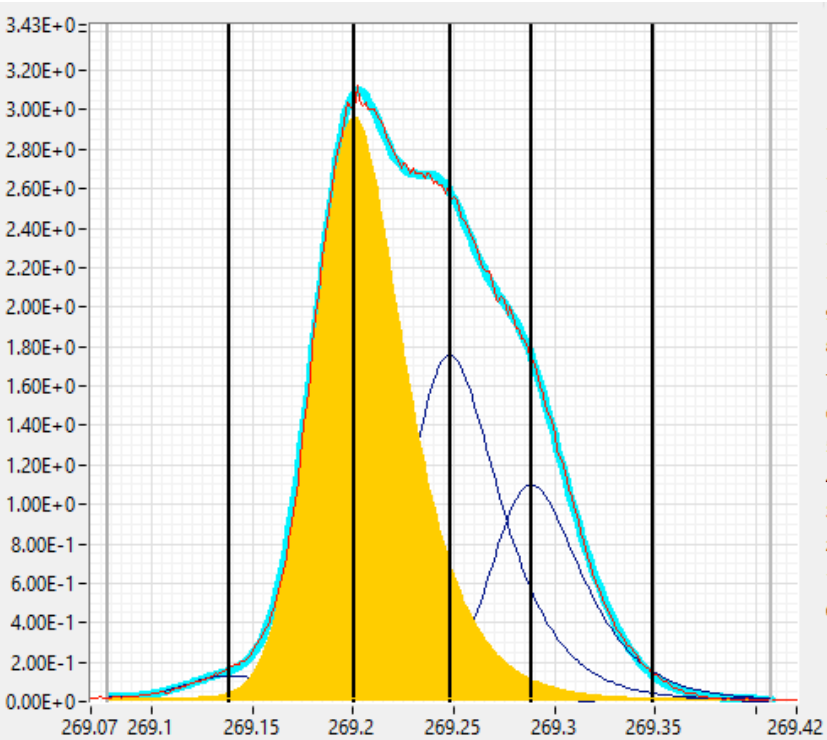

[M+H]⁺ : m/z 269.201

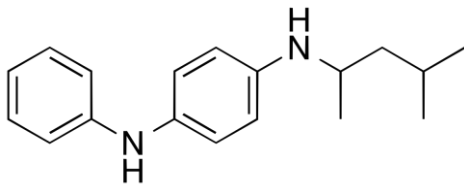

From on-line to off-line

- ~~0.02 mg/m³ LOOQ~~
- ~~20 minutes peak width~~

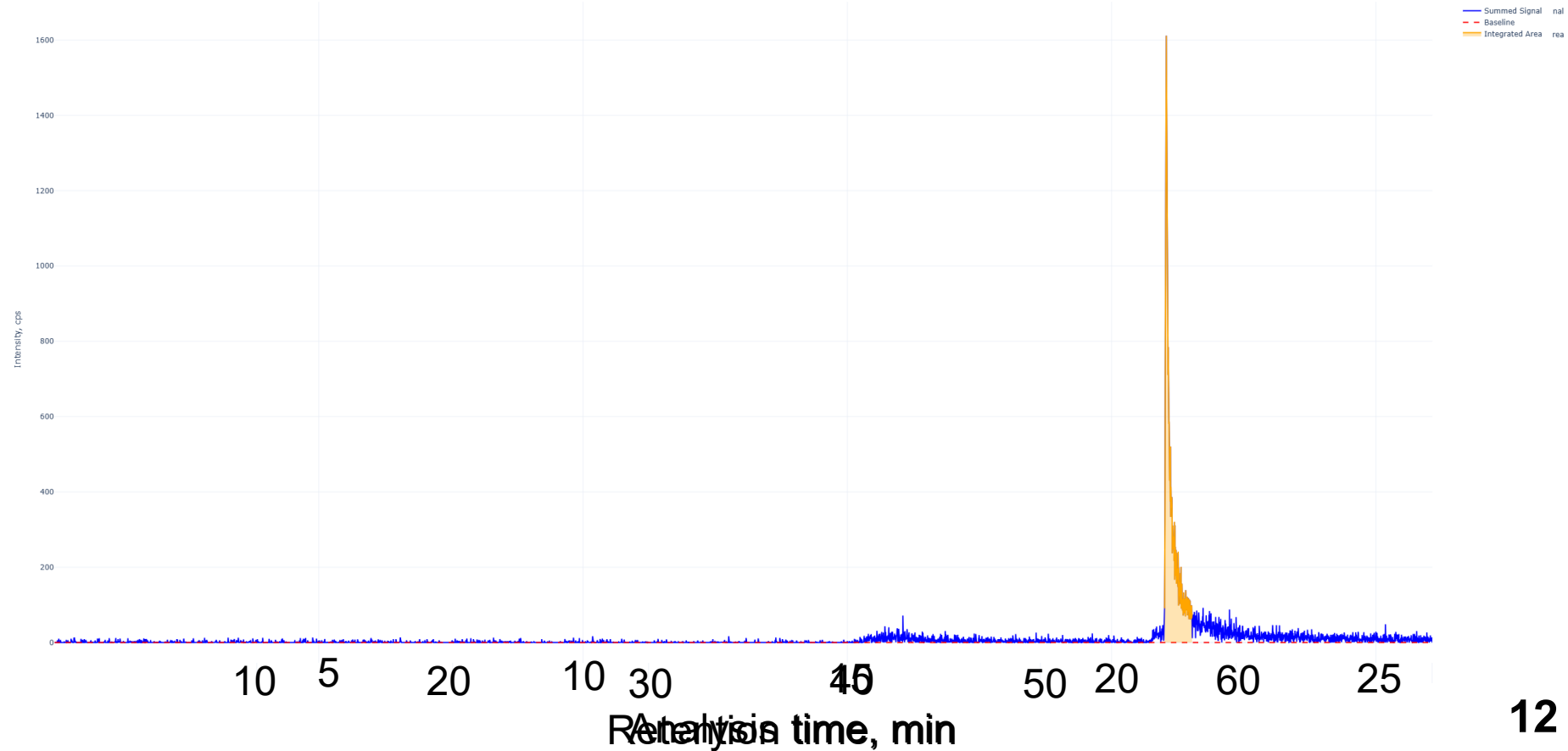

Home-made pyrolysis unit

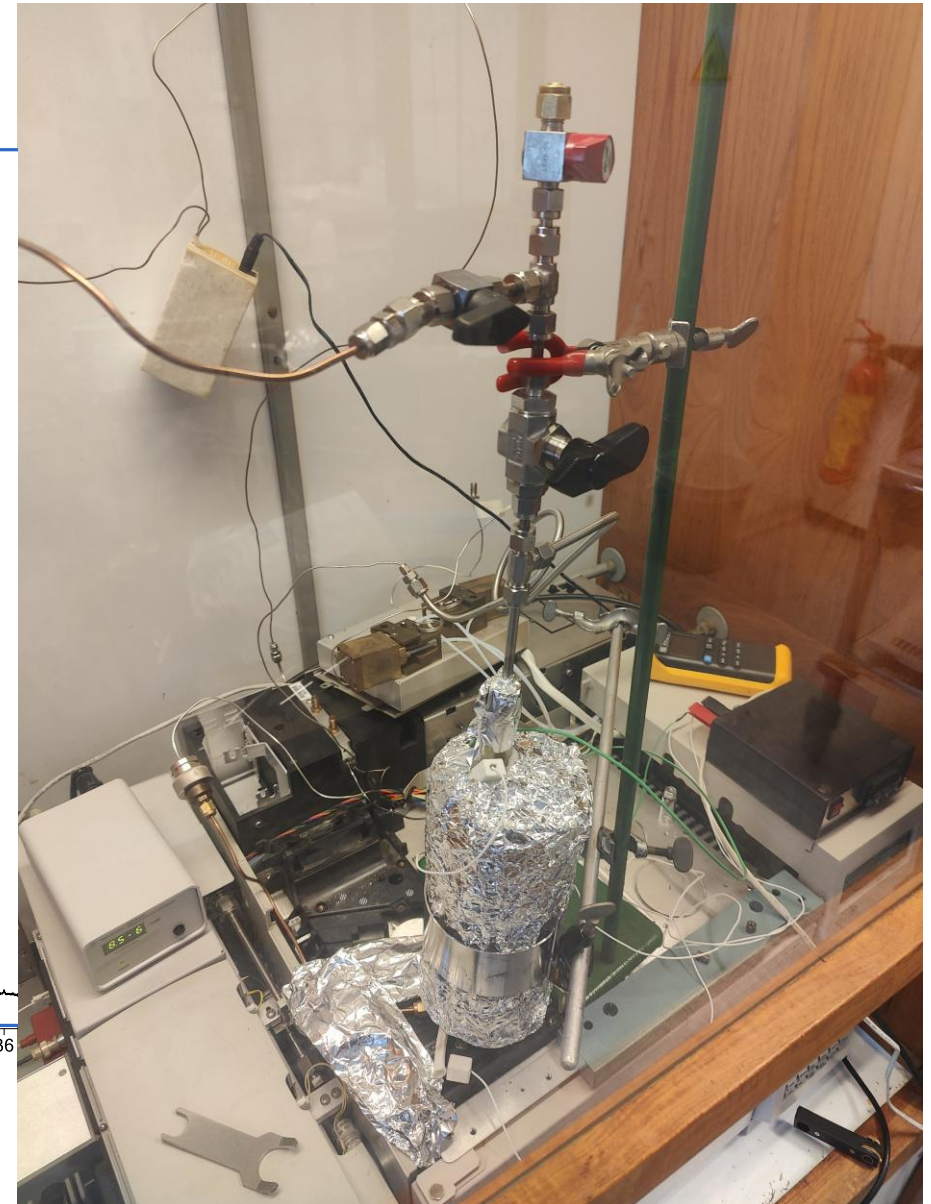
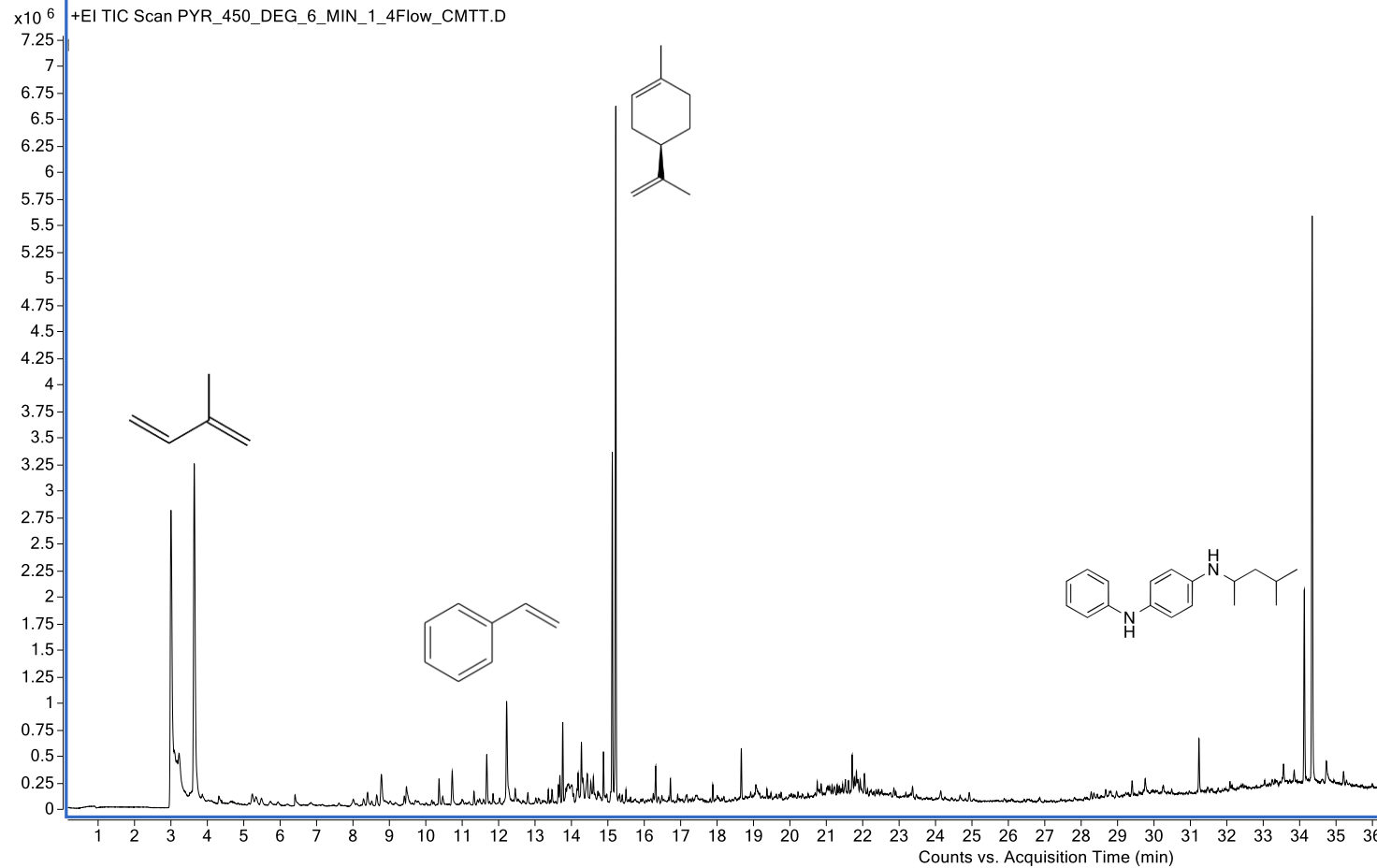

Temperature dependent degradation of 6PPD

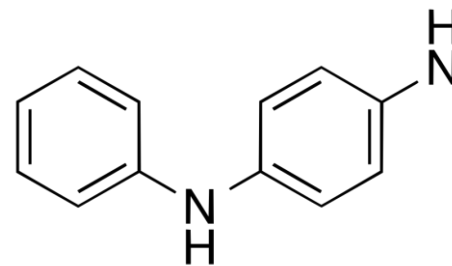
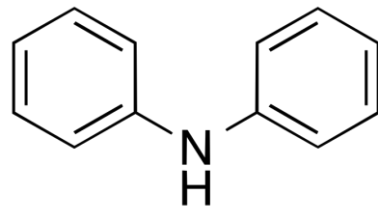
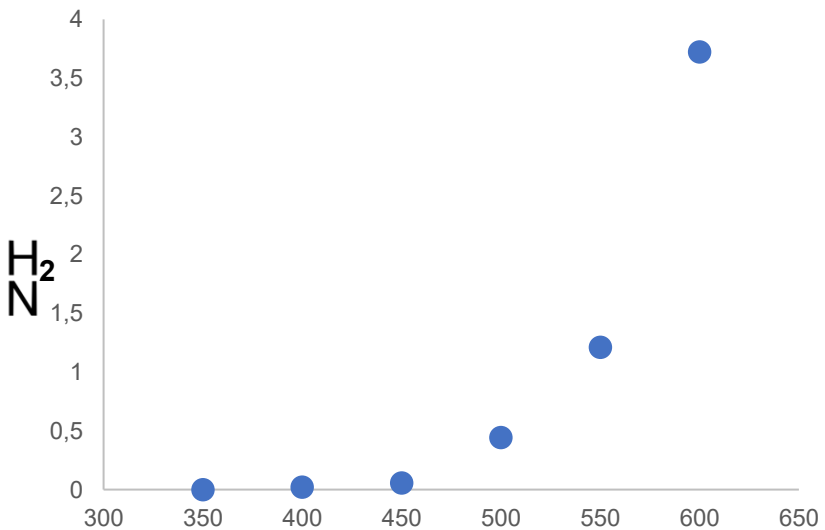
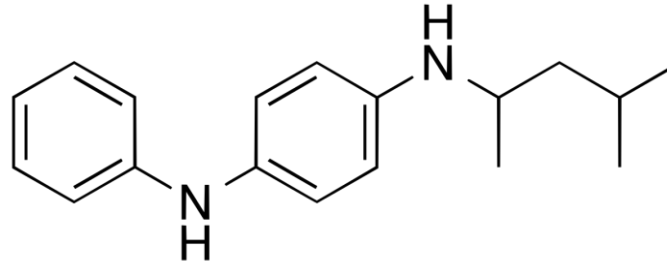
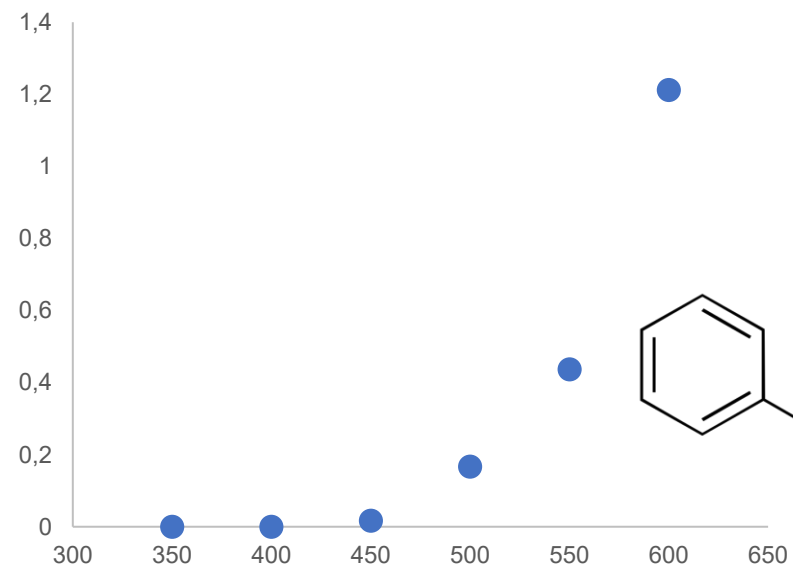
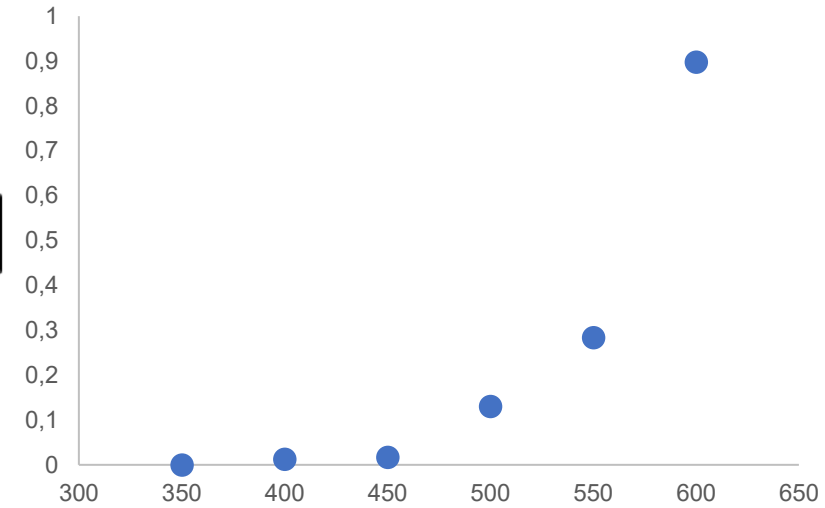
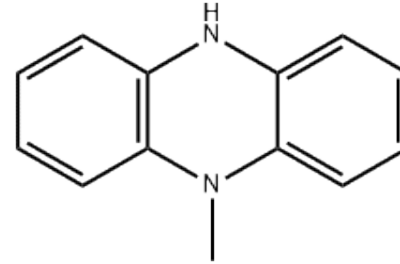
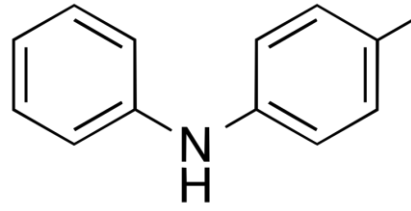
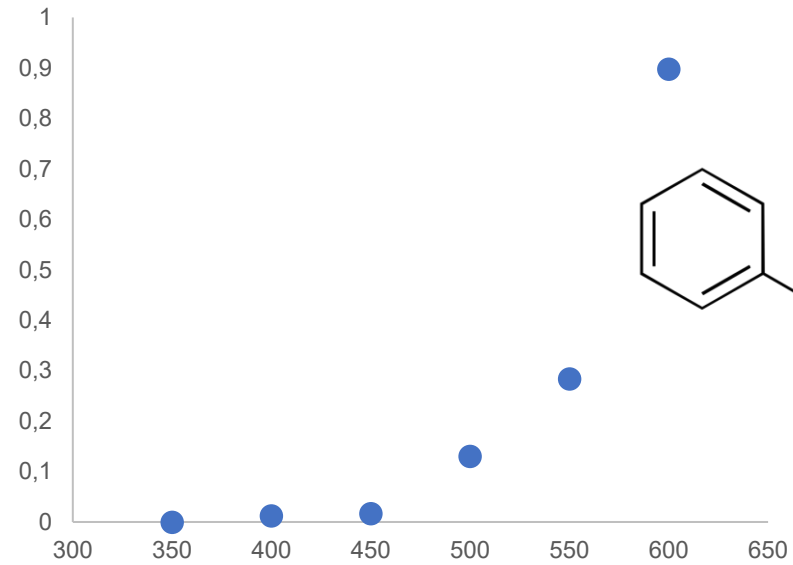

Drawbacks of Pyr-GC-MS

- Relatively poor sensitivity
(we've achieved so far about 10 ng/m³ – LOQ)
- Restricted amount of sample
- Thermal degradation of the compounds of interest
- Possible matrix effects

UHPLC-Orbitrap MS

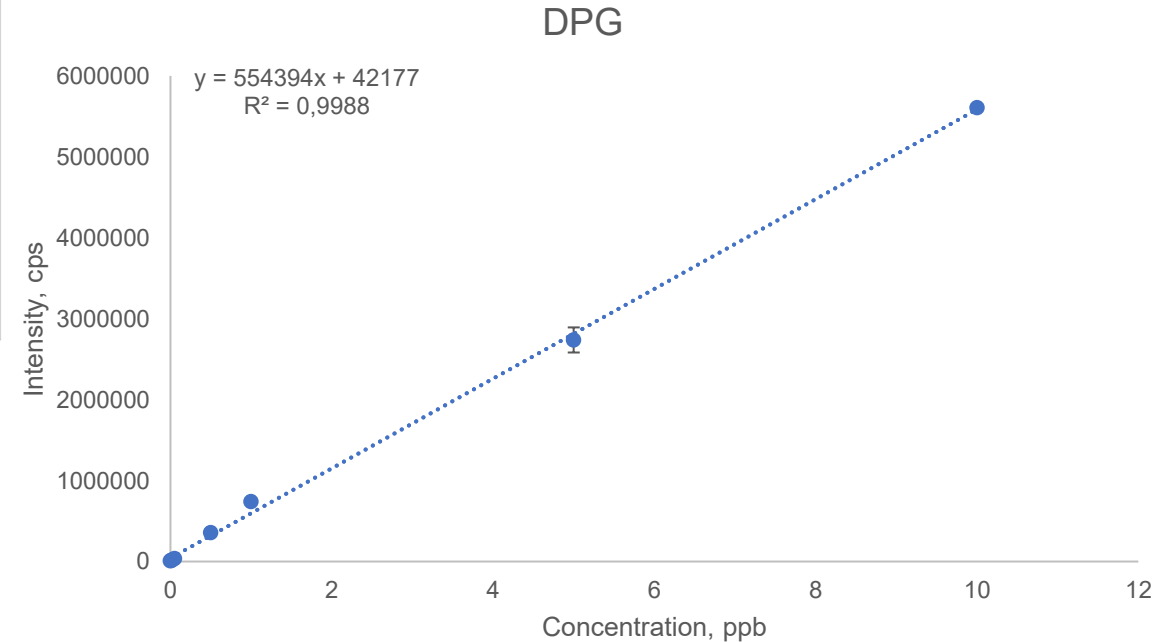
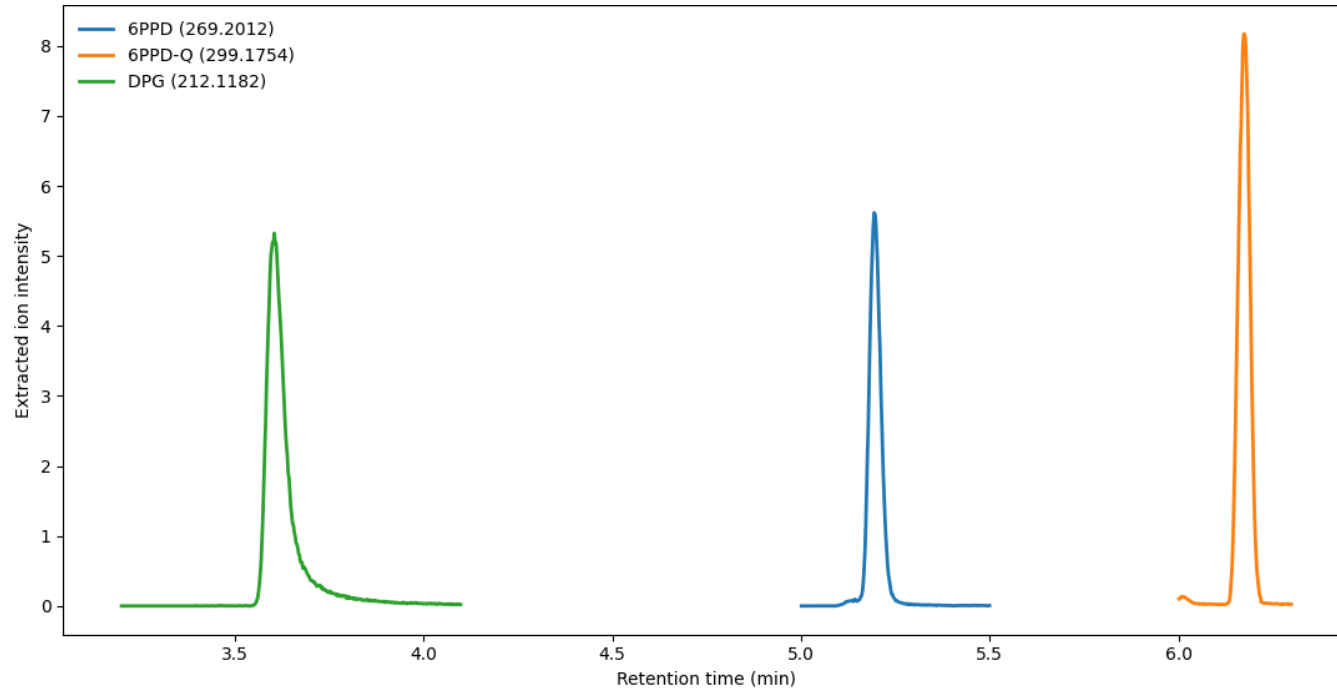

Total analysis time – 13 minutes

LOQ: 0.025 ppb – DPG, 0.1 ppb – 6PPD and 6PPDq

ESI+, H₂O-MeOH 0,1% FA,

Luna Omega Polar C18 1.6 um, 40 °C, 5 uL

Real sample analysis

Samples were collected at the
Department of Chemistry, UiO

48 m³ of air were collected on a quartz membrane filter

Filter and blank was extracted using ultrasonic bath at
40°C for 30 minutes in MeOH

Extract was then concentrated using gentle N₂ flow and
analyzed by UHPLC-Orbitrap

Analyte	Detected	LOQ
6PPD	0.3 ± 0.1 ng/m ³	0.01 ng/m ³
6PPDq	0.046 ± 0.01 ng/m ³	0.01 ng/m ³
DPG	0.86 ± 0.01 ng/m ³	0.003 ng/m ³

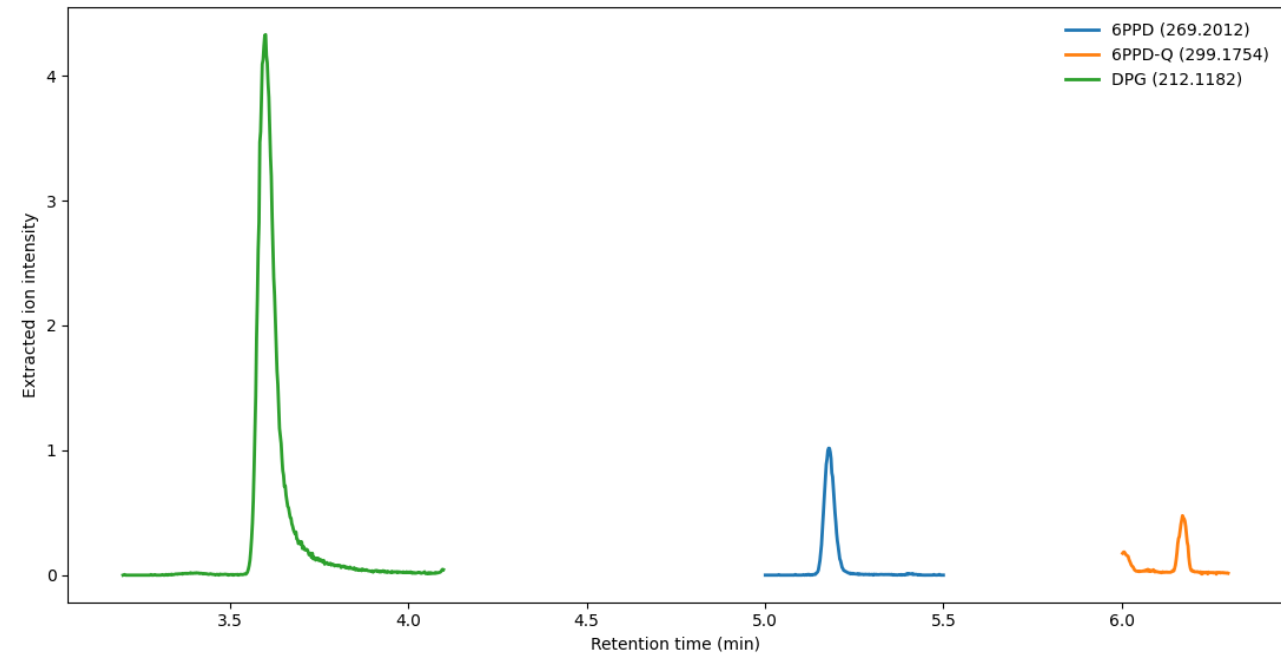

Additional Full Mass Scan Allowed us to identify:
5-Methyl-1H-benzotriazole
N,N'-di-2-naphthyl-p-phenylenediamine (DNPD)

Thank You for Your Attention

- This work was funded by the Research Council of Norway (NFR; Project No.: 334086; Airborne Microplastic Detection, Origin, Transport and Global Radiative Impact)